

\$ 1.50  
d18\inst\10inst

# INSTRUCTION MANUAL

FOR



Since 1929

## MECHANICAL POLAR PLANIMETERS

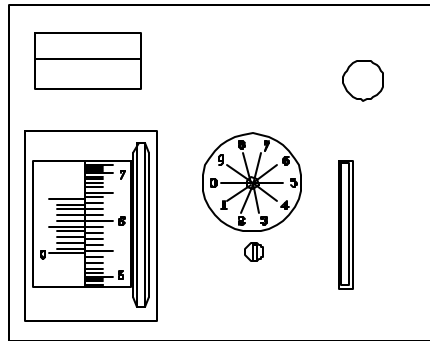

**LASICO**

LOS ANGELES SCIENTIFIC INSTRUMENT CO. INC.  
2451 RIVERSIDE DRIVE, LOS ANGELES, CA. - USA  
PHONE: (323) 662-2128 FAX : (323) 662-0904  
E-Mail : lasico @ worldnet.att.net Website: www.lasico.com

# INSTRUCTIONS FOR THE USE OF LASICO MECHANICAL POLAR PLANIMETERS

Thank you very much for selecting a Lasico Instrument.  
We hope it will serve you well for many years to come.  
Should you encounter any problems with the operation of your  
planimeter, please do not hesitate to contact us for assistance.

CONTENTS		
CHAPTER		PAGE
1.	The Measuring Operation	1
2.	The Polar Planimeter and its Components	2
2.1	Model Series 10 and 20	2
2.2	Model Series 30	2
3.	The Measuring Mechanism	3
4.	The Tracer Arm	4
4.1	The Measuring Resolution	4
4.2	The Measuring Range	4
5.	The Pole Arm	4
6.	Preparations	5
6.1	Setting the Tracer Arm Length	5
6.2	The Calibration Record	6
6.3	Determination of Measuring Constant $C_A$	7
7.	Instrument Testing and Recalibration	9
7.1	Test Procedure	9
7.2	Instrument Recalibration	9
8.	The Compensating Feature	10

**Instrument Warranty:**

Instruments proven defective in either workmanship or materials, will be repaired or replaced (at Lasico's option) free of charge within one year from the date of original purchase.

Lasico and its distributors shall have no liability of any kind, consequential or otherwise, resulting from the use or inability to use this product.

## 1. THE MEASURING OPERATION

1. Before any measurements are attempted, make sure that the measuring surface is suitable. It should not be very glossy, (photographs) too rough, mutilated, torn or patched up with adhesive tape. If the measuring surface is not quite suitable, cover it with a transparent sheet of tracing paper to minimize the problem. Make sure that the measuring table is reasonably flat and that both pole weight and planimeter body operate at the same elevation.

2. Assemble your instrument as shown on page 2 and if your instrument is a model 30, select the tracer arm length most suitable for your application. (please check page 5 for details)

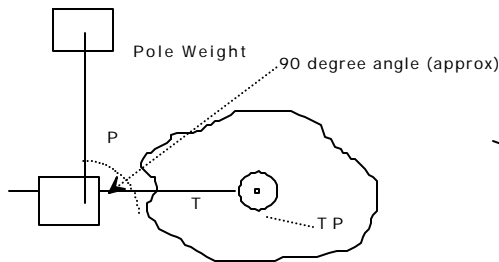

Fig. 1

3. Place the tracer point TP of your planimeter in the approximate center of the area to be measured. Position the pole weight in such a manner, that the pole arm P and the tracer arm T form a 90° angle (approx.) as shown in fig.1 below.

4. Make a quick cursory tracing around the area to be measured to make sure that the measuring wheel does not run over paper edges and that the area can be covered in one single continuous operation.

5. Select a starting point S somewhere on the area periphery and move the tracer point TP over it. (fig.2)

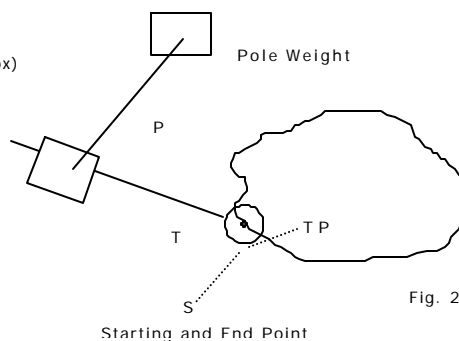

Fig. 2

6. Set the measuring mechanism to zero or take an initial reading.

7. While keeping the tracer point TP precisely over the peripheral line, move the tracer around the area in a clockwise direction until the circuit is closed and the starting point S is reached again. Important : While measuring, keep the instrument level on the measuring surface to avoid a lift off of the measuring wheel.

8. Read the result off the measuring mechanism. ( please check page 3 for details)

9. If the counter was cleared prior to the measuring process, the result "N" can

readily be used to obtain the actual area measurement.

10. If you took an initial readout prior to the measurement, it must be subtracted from the final readout to obtain "N".

11. For 1:1 measurements expressed in inch<sup>2</sup> or cm<sup>2</sup>, multiply the result "N" by the "u" value given for your model 10 or 20 or, if your instrument is a model 30, by the "u" value for the arm extension used.

( please check page 7 for details)

12. For scale measurements to be expressed in ft<sup>2</sup>, acres, mile<sup>2</sup>, m<sup>2</sup>, ha, km<sup>2</sup>, multiply "N" by C<sub>A</sub>. (= Scale Area Constant) Please check page 7.

## 2. THE POLAR PLANIMETER AND ITS COMPONENTS

### 2.1 MODEL SERIES 10 AND 20

Note: Series 10 and 20 planimeters are identical except for tracer arm length.

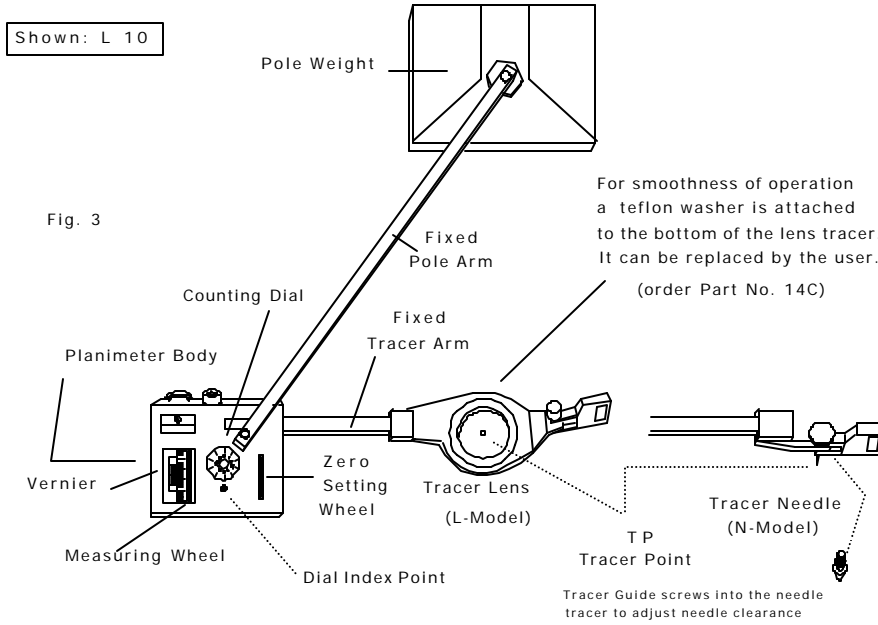

### 2.2 Model Series 30

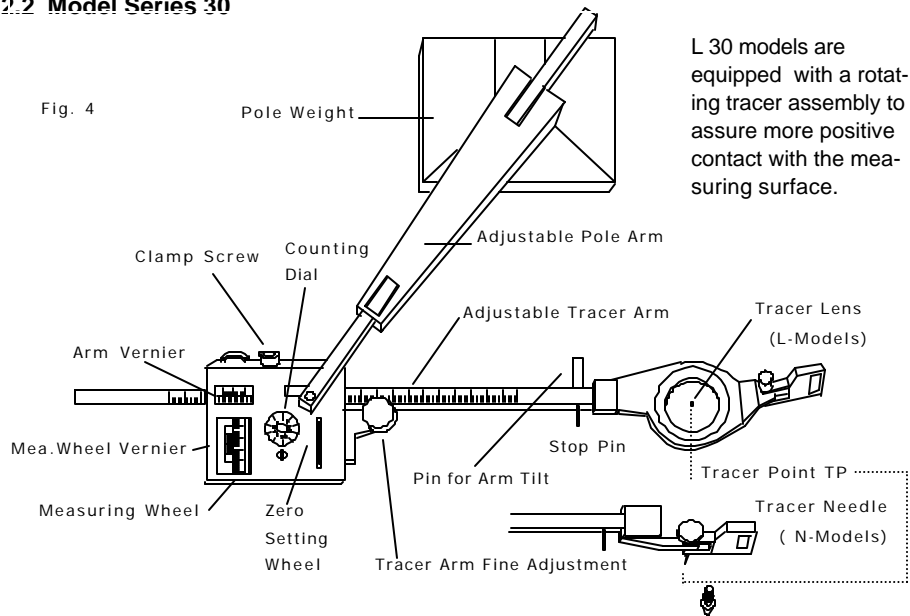

### 3. THE MEASURING MECHANISM

The measuring mechanism consists of a counting dial, a measuring wheel with 100 divisions, and a vernier. The counting capacity is 9999 .  
When measuring large areas, it is important to closely watch the counting dial and to add 10 000 to the readout for each complete turn of the dial.

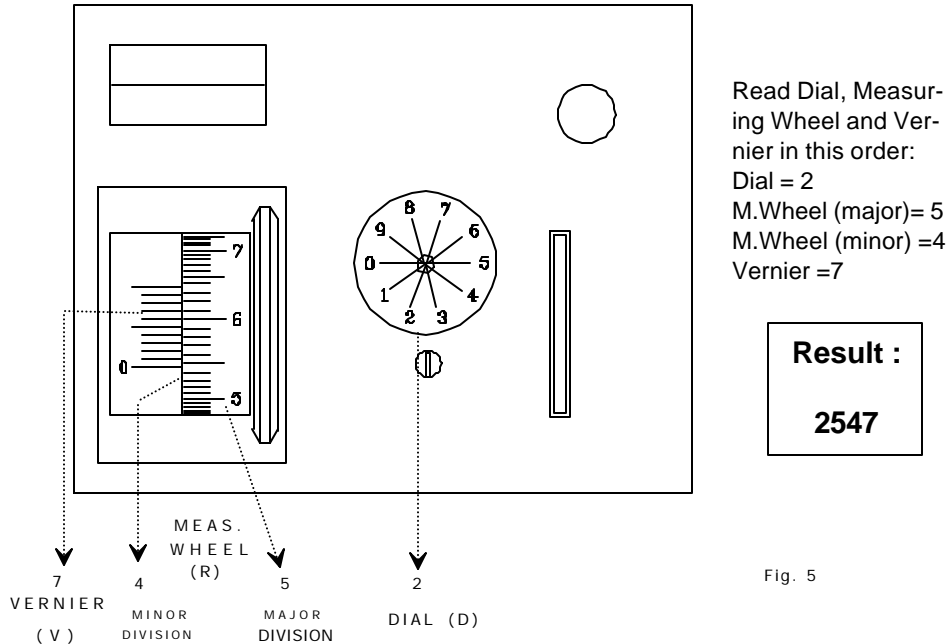

#### HOW TO READ A MECHANICAL PLANIMETER

The reading of a mechanical planimeter, is given on three different scales, as shown above. One of these is a flat dial, "D"; the second, "R" is attached to the measuring wheel; and the third is a stationary vernier scale, "V", located immediately next to the scale, "R". The disk provides the most significant digit, the scale attached to the measuring wheel provides the next two most significant digits, and the stationary vernier provides the least significant digit.

- To get the reading, first look at the disk, "D". Notice a small slotted-head screw that acts as pointer.
- If this pointer points between two numbers, then take the lower of the two as the most significant digit.
- If it points precisely at a number, then this number is the most significant digit provided that the next most

significant digit turns out to be either zero or almost zero; otherwise the next lower number is the most significant digit.

- Next, look at the scale, "R", on the measuring wheel. Notice that this scale has 10 major division markers that are numbered 0 to 9, and 10 small divisions between each numbered marker. Also look at the stationary scale, "V", and notice that it has a single major division marker labeled zero. This zero marker is the pointer to be used to read the scale.

- If this pointer points between two numbers, then the lower of the two numbers is the second most significant digit, except in one case. In this case, the marker points between 0 and 9; then 9 rather than 0 is the second most significant digit. If the pointer points right at a number, then that number is the second most significant figure, and the last two digits are zero's.
- If the vernier pointer points between two numbers on scale, "R", then it also points either at or between two of the ten minor divisions separating the numbered markers. If it points exactly at the third division for example then the third most significant digit is a 3 and the fourth is a 0. If it points between the third and fourth minor division, then the third most significant

digit is a 3 and the fourth digit must be obtained from the stationary vernier.

- Now notice that one line on the stationary vernier, "V", lines up best with one line on the measuring wheel scale, "R". This line on the vernier represents the least significant digit.
- This digit is found by counting up to it from the 0 vernier line. For example, if the seventh line on the vernier lines up best, then the last significant digit is a seven .(as seen in the example on page 3)

**Prior to any measurement**, you must "zero" the measuring mechanism or record the readout , which must then be subtracted from the final measuring result. To reset the mechanism to zero, use the zero setting wheel.

**If you have a model L 30**  
your instrument is equipped with a rotatable tracer. Depress the arm tilt pin with your right hand in order to lift the planimeter body off the measuring surface. Then, using your left hand, set the mechanism to zero by means of the zero setting wheel.

#### **4. THE TRACER ARM**

The length of the tracer arm is directly proportional to the measuring resolution and the measuring range of the planimeter.

##### **4.1 THE MEASURING RESOLUTION**

is the smallest area increment which the instrument can record. It is expressed as the "u" value. Model 10 and 20 planimeters have a fixed "u" value. The "u" value of model 30 can be altered by changing its tracer arm length. The highest resolution (=best accuracy) can be obtained by using the shortest arm extension.

##### **4.2 THE MEASURING RANGE**

is the area which can be covered by the instrument in one continuous tracing operation. To obtain max. measuring range set the tracer arm to its longest extension. (Mod. 30) If your instrument is equipped with an adjustable pole arm, it can also be used to extend the measuring range.

#### **5. THE POLE ARM**

does not affect the measuring resolution. Therefore adjustable pole arms can be set to any length desired. (using the customary "Pole Outside the figure" method.) The "pole inside method" is no longer used. All Lasico pole arms are supplied with a pole weight for work on any table surface.

## 6. PREPARATIONS

Before you start your measurements with a model 30 you need to optimize your instrument by choosing the tracer arm extension most suitable for your application.

Owners of model series 10 and 20 instruments have no choice, since the tracer arm length is fixed.

The readout results of mechanical planimeters are expressed in planimeter units and they need to be processed in order to obtain true area values.

Therefore it is necessary to prepare a special measuring constant ( $C_A$ ) to compensate for a scale ratio or to select the appropriate "u" value for 1:1 measurements.

### 6.1 TRACER ARM LENGTH

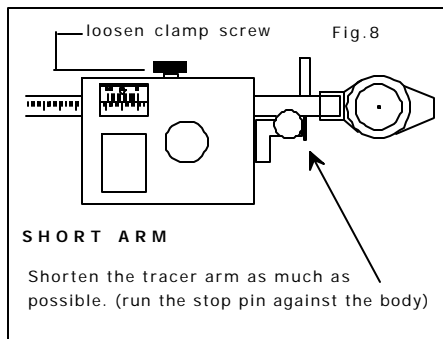
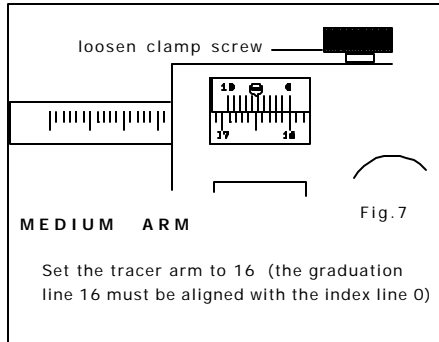
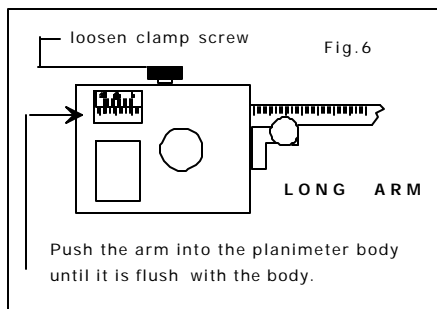

#### SERIES 10/20 PLANIMETERS

have a fixed resolution and range, limiting the use of the instrument to some extent.

#### SERIES 30 PLANIMETERS

give you the choice to configure the instrument for maximum accuracy by selecting a short tracer arm extension or for maximum measuring range by selecting a long arm. In addition it is possible to use a compromise setting (medium arm).

Furthermore, all model 30 planimeters are calibrated to provide 1:1 measurements directly in  $\text{inch}^2$  and  $\text{cm}^2$  by using a precalibrated arm setting. (check next page)

#### IMPORTANT:

For maximum precision always use the shortest arm length possible. This is especially important, if the areas to be measured are smaller than  $1 \text{ in}^2 / 6 \text{ cm}^2$ .

If the size of the area makes it necessary to subdivide it for evaluation, then you should use a long arm which permits measurements in one (or as few as possible) continuous tracing operations.

Model 30 Planimeter Tracer Arm Extensions can be quickly changed as shown on the left side of this page.

Tracer arm settings for 1:1 inch and 1:1 cm results are shown in your calibration records. How to adjust the tracer arm length to these values is shown on page 6.

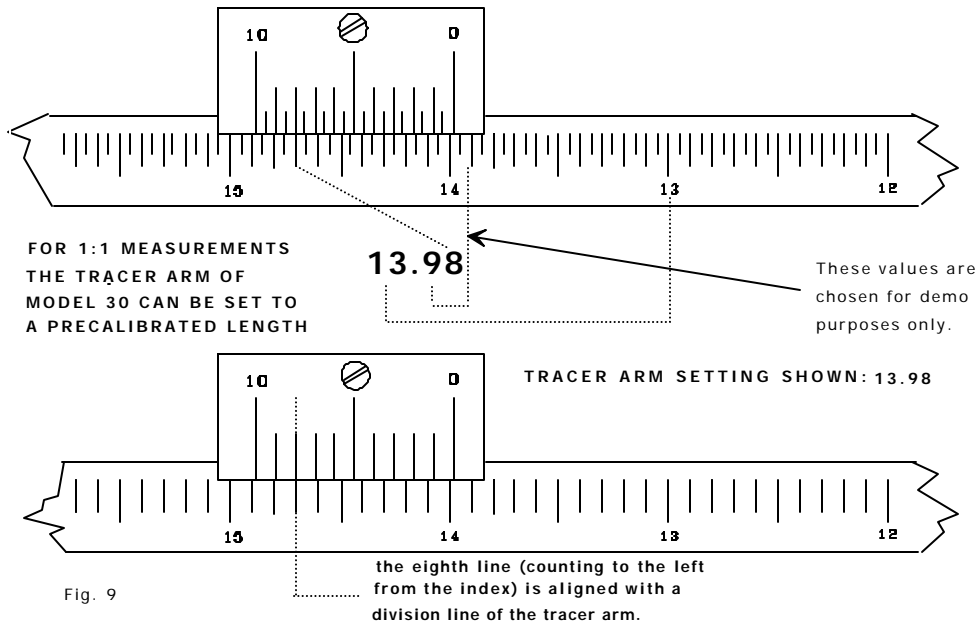

The tracer arm of your model 30 may be graduated in mm or half mm intervals. If you have half mm intervals, simply ignore the half mm divisions and set the arm length using only the mm lines. The line drawings above show a setting of 13.98 cm. Full cm and the 1/10<sup>th</sup> cm graduation lines are located to the right of the index line 0. The 1/100<sup>th</sup> cm division is the vernier line (always to the left of the index line 0), which is best aligned with a dividing line of the arm.

## 6.2 THE CALIBRATION RECORD

A Calibration Record is supplied with every planimeter.. It shows the "u" values of the instrument, which are needed to determine the measuring constants.

**Example of a Model 30 Calibration Record:** (varies between instruments)

LONG TRACER ARM	u - (English) _____ 0.02010 u - (Metric) _____ 0.12971	"u" values for several arm extension are provided to assure maximum flexibility and optimal results.
MEDIUM TRACER ARM	u - (English) _____ 0.01368 u - (Metric) _____ 0.08831	
SHORT TRACER ARM	u - (English) _____ 0.00878 u - (Metric) _____ 0.05669	
TEST AREA	A <sub>T</sub> (English) _____ A <sub>T</sub> (Metric) _____	
TRACER ARM SETTING for 1:1 MEASUREMENTS	for u = 0.01 in <sup>2</sup> ....12.07 for u = 0.1 cm <sup>2</sup> ....17.99	

Values shown are for demo purposes only. Yours may be different !

### Example Of A Model 10 / 20 Calibration Record

Models	u-Value (English)	u-Value (Metric)
10 / 10A	0.01 in <sup>2</sup>	0.0645 cm <sup>2</sup>
20 / 20A	0.02 in <sup>2</sup>	0.129 cm <sup>2</sup>
20M /20AM	0.015 in <sup>2</sup>	0.1 cm <sup>2</sup>

### 6.3 DETERMINATION OF THE AREA MEASURING CONSTANT C<sub>A</sub> .

After finishing the measuring operation, the readout result must be multiplied by C<sub>A</sub> in order to obtain the true area value.

**For 1:1 Measurements,**  $C_A = u$  ; i.e. the user simply multiplies his or her

readout result by the u-value of the instrument in use. If the instrument is a fixed arm model 10 or 20, the u-values can be obtained from the Calibration Records (see example shown above).

If the instrument is a model 30, it is necessary to use the u-value specified for the tracer arm extension used. (please check the previous page) .

#### Example:

A figure is to be measured directly in sq.inches. The instrument used is a Mod. L10.

The u-value for a Model 10 is 0.01. Subsequently all readout results must be multiplied by 0.01 in order to obtain the result in sq. inches.

If the readout result is 4562, the true area result is  $4562 \times 0.01 = \underline{45.62 \text{ in}^2}$  ;

**For Measurements of Scaled Areas,** the C<sub>A</sub> value must be determined.

The following formula applies:  $C_A = S_c^2 \times u$  ; where S<sub>c</sub> is the scale ratio

expressed as an engineering ratio.

Again, the u-value entered into this formula is always the same if a model 10 or 20 is used.

However if the instrument is a Model 30, it is necessary to use the u-value specified for the tracer arm extension used. (please check the previous page) .

#### Example:

The square footage of a land parcel is needed. Scale ratio is 1"= 40' ; The Planimeter model used is a L 30 with medium arm extension.

Therefore  $C_A = 40^2 \times 0.01368 = 1600 \times 0.01368 = \underline{21.89 \text{ ft}^2}$  ;

Please note: You find the u-value entered into the formula in your Calibration Records. The u-value shown here was extracted from the example records on the previous page. However your u-values may be different .

**Example:**

Planimeter used: Model 30; Scale ratio : 1" = 660 feet; Long Arm Extension used; Results to be expressed in Acres.

The formula for determination of the Acre Constant :  $C_A = \frac{Sc^2 \times u}{43560}$  ;

Subsequently  $C_A = \frac{660^2 \times 0.02}{43560} = \underline{0.2 \text{ Acres}}$  ;

**Example:**

Planimeter used: Model L20M; Scale ratio = 1 : 5500; Results needed in sq. meters. All metric scale ratios are expressed in proportional ratios. 1:5500 means that 1 cm = 5500 cm. Since the result must be expressed in sq.m, we need to convert the scale ratio accordingly: i.e. 1 cm = 5500 cm or 1 cm = 55m;

Therefore  $C_A = 55^2 \times 0.1 = \underline{302.5 \text{ m}^2}$ ; ( 0.1 is the u-value for model 20M)

**Important**

Please keep in mind, that all values used in computing  $C_A$  must be of the same unit value, i.e. if results are needed in mile<sup>2</sup>, a foot scale ratio must first be converted into a mile ratio. etc.

If your scale ratio is an architectural ratio, please check below.

**Architectural Scale Ratios**

like 1/32" = 1' or 3/4" = 1' must be converted into an Engineering Ratio Sc before they can be used to determine  $C_A$ .

- 1/32" = 1' converts to 1" = 32'
- 1/16" = 1' converts to 1" = 16'
- 1/8" = 1' converts to 1" = 8'
- 3/8" = 1' converts to 1" = 2.666'
- 1/2" = 1' converts to 1" = 2'

**Special Scale Ratios**

In some instances, ( when measuring cross sections, etc.) it is possible, that the horizontal scale is different from the vertical scale.

The basic  $C_A$  formula is slightly altered to :  $C_A = (h \times v) \times u$  ;

where h is the horizontal and v the vertical scale.

**Example**

h : 1"= 40' and v : 1"=20'. u = 0.01; Therefore  $C_A = 40 \times 20 \times 0.01 = 8 \text{ ft}^2$  ;

## 7. INSTRUMENT TESTING AND RECALIBRATION

Any area of known size can be used for instrument testing or recalibration. However since freehand tracing will inevitably introduce tracing errors, it is essential that multiple tracings are performed and averaged .

### 7.1 Test Procedure

- We recommend to draw a 4 x 4 inch square if your instrument is calibrated for English (imperial) measuring units or a 10x10 cm square, if you use the metric system.
- Measure the area as outlined on page 1.
- Obtain the readout result "N" from the measuring mechanism

- Multiply the readout (N) of Model 10/10A by 0.01
  - Model 20 / 20 by 0.02
  - Model 20M/20AM by 0.1
  - Model 30 by the u-values shown in the calibration records. (depending on arm extension used.)
- The results must be 16 in<sup>2</sup> for instruments calibrated in English units and 100 cm<sup>2</sup> for metric planimeters.

### 7.2 Instrument Recalibration

The planimeter can easily be recalibrated by the user. Recalibration may become necessary if an instrument was dropped and knocked out of adjustment or if the Calibration Records were lost.

You may recalibrate by drawing a precise square or rectangle on a sheet of paper. (we recommend to draw a 4x 4 inch or a 10 x 10 cm square.)

#### **Models 10/20 :**

- Measure the test area and multiply result (N) by your u-value.
- If the result is too low, reduce the length of the tracer arm, if it is too high, lengthen it.
- Subsequently, slightly loosen the two tracer arm lock screws on the bottom of the planimeter (Fig.10). Lengthen or shorten the arm length depending on the result obtained before . Measure again, etc. Repeat until result is ok. Secure lock screws again.

**Model 30 :**To find the tracer arm settings for 1:1 measurements, we proceed as outlined.

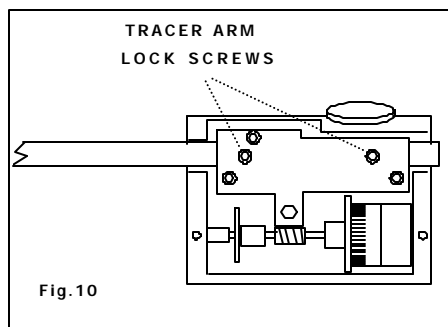

Fig. 10

- Measure the test area and multiply the readout result " N " by  $u = 0.01$  (English) or by  $u = 0.1$  (Metric)
- If the result is too low, reduce the tracer arm length, measure, change arm length again, measure, etc. until result is ok. Record the setting of your arm.
- If the measuring result was too high, lengthen the arm. Repeat this procedure until the readout result multiplied by  $u$  equals the value of your test area.
- For Scale Measurements using short, medium or long arm extensions, we must determine new u-values.
- Select the short tracer arm extension. Measure the test area. Readout result is designated as "N" ;

- Determine u- value with formula:

$$u = \frac{A_T}{N}; \quad \text{where } A_T = \text{size of test area.}$$

*Example :*

If your test area is a 4 x 4 inch square, and the readout result was 1725, then your new u-value is

$$u = \frac{16}{1725} = \underline{0.00927 \text{ in}^2}$$

- Use the same procedure to determine new u-values for the medium and long tracer arm.
- Record the new u-values.

## 8. THE COMPENSATING FEATURE

To compensate for tracing errors, it is advisable to measure areas twice and to use the average of both results.

To compensate for instrumental and tracing errors, you may want to employ the compensating feature of your instrument.

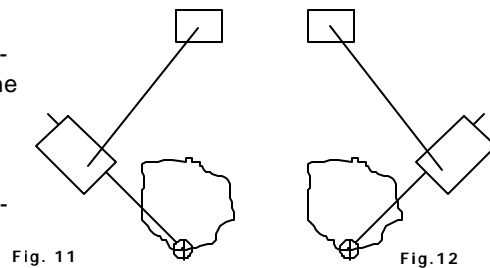

The area of a figure must be measured first with the tracer point to the right of the pole arm, (Fig.11) and then with the tracer point to the left of the pole arm. (Fig.12) The position of the pole weight must be identical for both measurements.

The readout results must subsequently be averaged.

## 9. TIPS AND HINTS

Lasico Planimeters are no longer calibrated for the inferior "Pole inside the figure " method, which provided a larger measuring range.

Instead we recommend to subdivide areas which cannot be measured in one continuous operation, into smaller sections and to measure them separately.

Avoid extreme temperature conditions, since material expansion or shrinkage (of both instrument and drawing) can cause sizable measuring errors.

If a planimeter was stored at low temperatures, loosen up its measuring mechanism by moving the instrument around in a circular motion until the measuring wheel rotates freely.

The length of the pole arm does not affect the result of a measurement. Therefore you can set it to any extension desired. A longer pole arm provides a larger measuring range.

To protect the instrument and especially the delicate needle bearings from damage, always lower the planimeter gently onto the table surface. Keep the instrument in its protective case if it is not used.

Protect it from dust, dirt and excessive humidity and do not touch the rim of the measuring wheel. The measuring wheel must always spin freely.

If dust accumulates anywhere in the measuring mechanism or the ball socket of the pole arm, remove it with a Q-tip . Apply a few drops of fine watch oil to bearings and ball sockets every 2 years.