

# BRIEF INSTRUCTIONS

## FOR LASICO MODEL 42P and 42C PLANIMETERS

t3\inst\brief42a

More detailed information on the operation of your instrument can be found in your Instruction Manual. However, these Brief Instructions cover the most essential points and should get you started in a hurry.

### - INSTRUMENT SETUP

#### Prepare the processor for operation

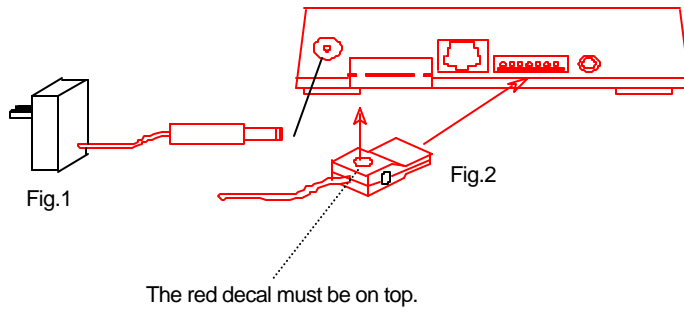

✓ Plug the power supply into a wall outlet and the DC plug into the power jack of the processor . (fig.1 )

✓ Insert the encoder plug into the encoder receptacle. The red decal located on the plug must point up. (fig.2)

#### Prepare the planimeter for operation

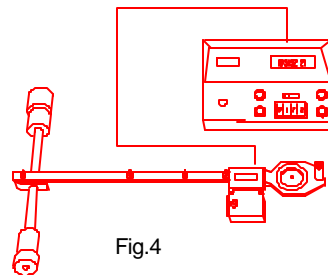
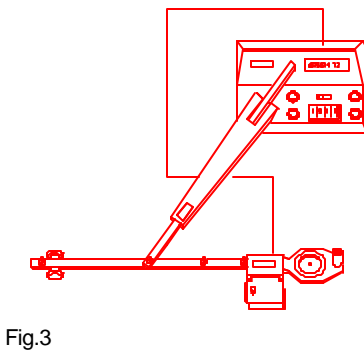

✓ Assemble Model 42P as shown in fig.3

✓ Assemble Model 42C as shown in fig.4

In order to optimize the instrument for best accuracy or measuring range, the Models 42P and 42C are equipped with adjustable tracer arms. Thus the user can select the arm length most suitable for the specific application.

**Very Short and Short :** For small and medium sized areas. It provides the greatest accuracy level.

**Medium:** For medium areas

**Long:** For large areas

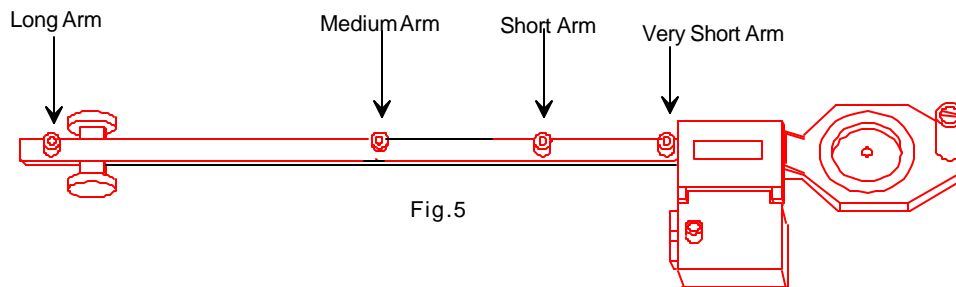

Simply engage the pole arm post into either the long, medium, short or very short arm receptacle. If a carriage is used (model 42 C), engage the carriage pin into either the long or medium arm receptacle. Do not use the carriage with the short or very short arm extension. Use the pole arm supplied with these instruments instead.

## - INSTALLATION OF THE SCALE CONSTANT

Series 42 Planimeters are supplied with a Calibration Record, which includes readily computed Measuring Constants for common English /Imperial scale ratios. For work with Metric measuring units please check below:

| CALIBRAT.DATA       | V. SHORT ARM       | SHORT ARM        | MEDIUM ARM       | LONG ARM         | L. VALUES        |
|---------------------|--------------------|------------------|------------------|------------------|------------------|
| RT                  | 2127               | 1296             | 725              | 503              | RL-VALUES        |
| U (ENGL)            | 0.0059             | 0.00969          | 0.0173           | 0.0249           | ENGL.433         |
| U (METRIC)          | 0.0380             | 0.0625           | 0.1117           | 0.1610           | METR.170.4       |
| <b>Scale Ratios</b> | <b>Ca - Values</b> | <b>Ca-Values</b> | <b>Ca-Values</b> | <b>Ca-Values</b> | <b>CI-Values</b> |
| 1"=1"               | 0.0059             | 0.0096           | 0.0173           | 0.0249           | 0.0023           |
| 1/32"=1'            | 6.0467             | 9.9239           | 17.7399          | 25.5695          | 0.0739           |
| 1/16"= 1'           | 1.5116             | 2.4809           | 4.4349           | 6.3923           | 0.0370           |
| 1"=10'              | 0.5905             | 0.9691           | 1.7324           | 2.4970           | 0.0231           |
| 1"=20'              | 2.3620             | 3.8765           | 6.9296           | 9.9880           | 0.0462           |
| 1"=40'              | 9.4480             | 15.5062          | 27.7186          | 39.9523          | 0.0924           |

ETC.

Let us assume you want to use the long arm for your application, simply enter the Metric **U-value** for this arm length into the formula used for determination of Constant **Ca**.

The Formula used to determine the Calibration Constant **Ca** :

$$Ca = Sc^2 \times U;$$

Where:  
 Sc = Scale Ratio  
 U = Value of one

**Examples:** (based on the U-Value of the long arm)

- For 1:1 measurements in cm<sup>2</sup> enter the U-value into the processor . Ca = 0.1610;
- For a scale of 1:5000 and results in m<sup>2</sup> :  
 Ca = 50<sup>2</sup> x 0.1610 = 402.5

### Program the Ca-Value into the processor

Enter 402.5 into the scaler switches

4 0 2 5 , turn processor off and

on again. Then push the decimal button until 402.5 is shown on the display.

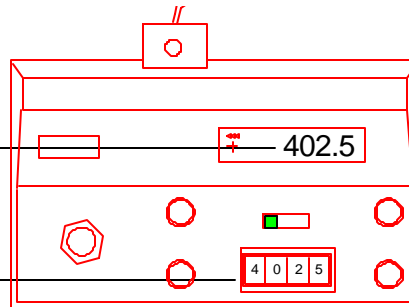

Fig.6

## - THE MEASURING OPERATION

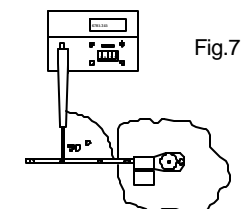

Fig.7

✓ Position the instrument tracer in the approximate center of the area to be measured and align pole and tracer arms at a 90° angle.(approx.)  
 fig.7

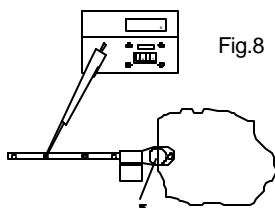

Fig.8

✓ Select a starting point "S" somewhere on the periphery of the area and position the tracer point over it.fig.8  
 ✓ Clear the display with the CL switch of your processor.  
 ✓ Move the tracer point around the area in a clockwise direction until the starting point is reached again.

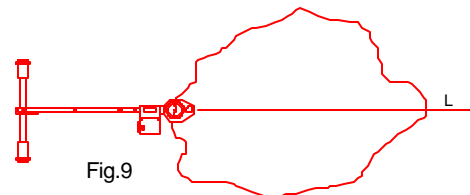

Fig.9

42C models should be set up as shown in fig.9 over an imaginary line L which goes through the center of the area.  
 ✓ Select a starting point, clear the display and guide the tracer around the area until the starting point is reached again.